



# Quick Start Guide

## WI-I/O 9-L-T Wireless I/O Transmitter Unit

## About this document

This document is the *WI-I/O 9-L-T Wireless I/O Transmitter Unit Quick Start Guide* and contains the following sections:

Section	Read this section if you want to ...
<b>Basic steps for using your unit</b>	Learn the basic steps for installing and using your unit.
<b>Factory default configuration</b>	Understand how the transmitter sends information to the receiver.
<b>Unit components</b>	Understand the different parts of your unit.
<b>Antenna installation</b>	Learn how to install an antenna with your unit.
<b>Resetting factory defaults</b>	Reset your unit to the original factory default settings.
<b>Linking transmitter and receiver units</b>	Link your units to work as a dedicated pair.
<b>Safety information</b>	Understand important safety information related to your unit. <b>NOTE:</b> You must read this information before installing your unit.
<b>Specifications</b>	Know technical information about your unit.

For more information, see the next sections.

## Basic steps for using your unit

This document describes how to configure your unit using the default factory configuration that lets you easily setup your network as a simple send/receive network using a dedicated pair of transmitter and receiver units.

The basic steps for using your unit are:

1. Connect the antenna, power supply and transducer signals using the instructions in this document. Power supply and transducer connection is described in the section ***Unit components and connections***. Antenna connection is described in the section ***Antenna installation***. For more information, see the ***WI-I/O 9-L-x Install Manual***.
2. Reset the transmitter and receiver units to the factory default configurations.
3. Link the transmitter and receiver units to work as a dedicated pair.
4. Bench test your configuration before deploying.

**NOTE:** You can also configure your network using a user-defined customised configuration that lets you set specific information about your network. For more information on setting a user-defined customised configuration, see the ***WI-I/O 9-L-x User Manual*** on the enclosed CD.

## Factory default configuration

When you configure the units using the configuration in this document, the inputs from the transmitter are sent to the outputs at the receiver as follows:

WI-I/O 9-L-T (Transmitter)	Sends	WI-I/O 9-L-R (Receiver)
Digital Input 1	⇒	Digital Output 1
Digital Input 2	⇒	Digital Output 2
Analogue Setpoint	⇒	Digital Output 3
Analogue input (4-20 mA)	⇒	Analog output
Thermocouple Input (Not used)		Communication Failure (Comes on if no messages from WI-I/O 9-L-T)
Setpoint Output (Local indication)		
System OK (On if system OK)		System OK (On if system OK)

## Unit components and connections

Your WI-I/O 9-L-T transmitter unit has the following components and terminal connections:

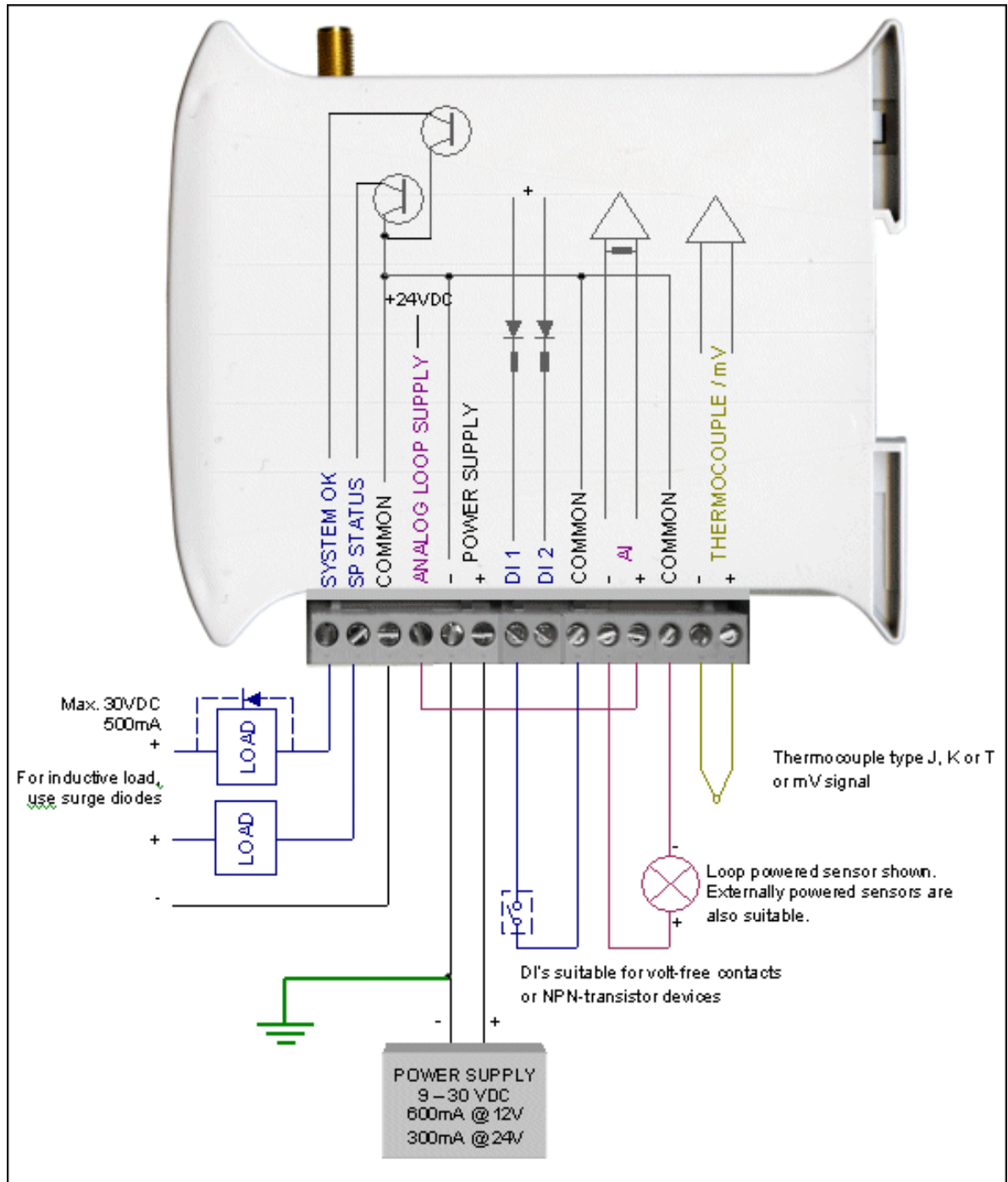

### **\*\*IMPORTANT ELECTRICAL SAFETY INFORMATION\*\***

In order to comply with Electrical Safety Regulations, this module must be installed in an Electrical AND Fire enclosure. This enclosure may be a single or multiple enclosures. Access to the module is to be made by a Service Person only.

The front panel contains the following components:

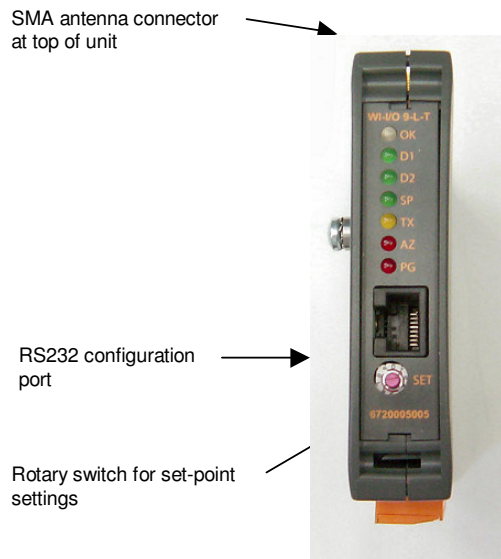

The triangle on the rotary switch indicates the current position, for example:

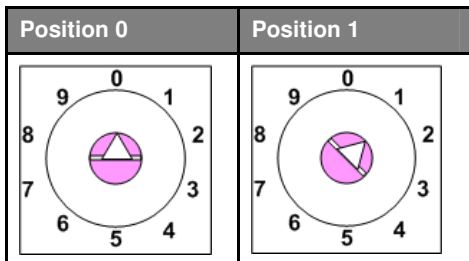

**NOTE:** To avoid damaging the rotary switch, use a screwdriver to change the position.

The rotary switch uses the following setpoint levels:

Position	Lower level (mA)	Upper level (mA)
1	4.8	6.4
2	6.4	8.0
3	8.0	9.6
4	9.6	11.2
5	11.2	12.8
6	12.8	14.4
7	14.4	16.0
8	16.0	17.6
9	17.6	19.2

The LEDs on the front panel indicate the unit status:

LED Status	Indicates	
<b>None</b>	No power supply.	
<b>OK LED Green</b>	Current status of the unit OK.	
<b>OK LED Red</b>	Fault condition detected in unit.	
<b>TX Led Flashes</b>	Transmitting Message.	
<b>PG LED on</b>	Configuration Cable Connected.	
<b>Input LED ON</b>	Input LEDs (i.e. D1,D2, SP, AZ.) light when the corresponding input is active.	
	D1	Digital Input 1 is active (Low).
	D2	Digital Input 2 is active.
	SP	Analog Setpoint is active.
	AZ	Analog Input is zero mA
<b>All LEDs medium flash</b>	Medium speed flash (1.6HZ) indicates the module is half-way through the configuration process. Medium flash also happens when you set the rotary switch to position 0 when powering on the unit.	

## Antenna installation

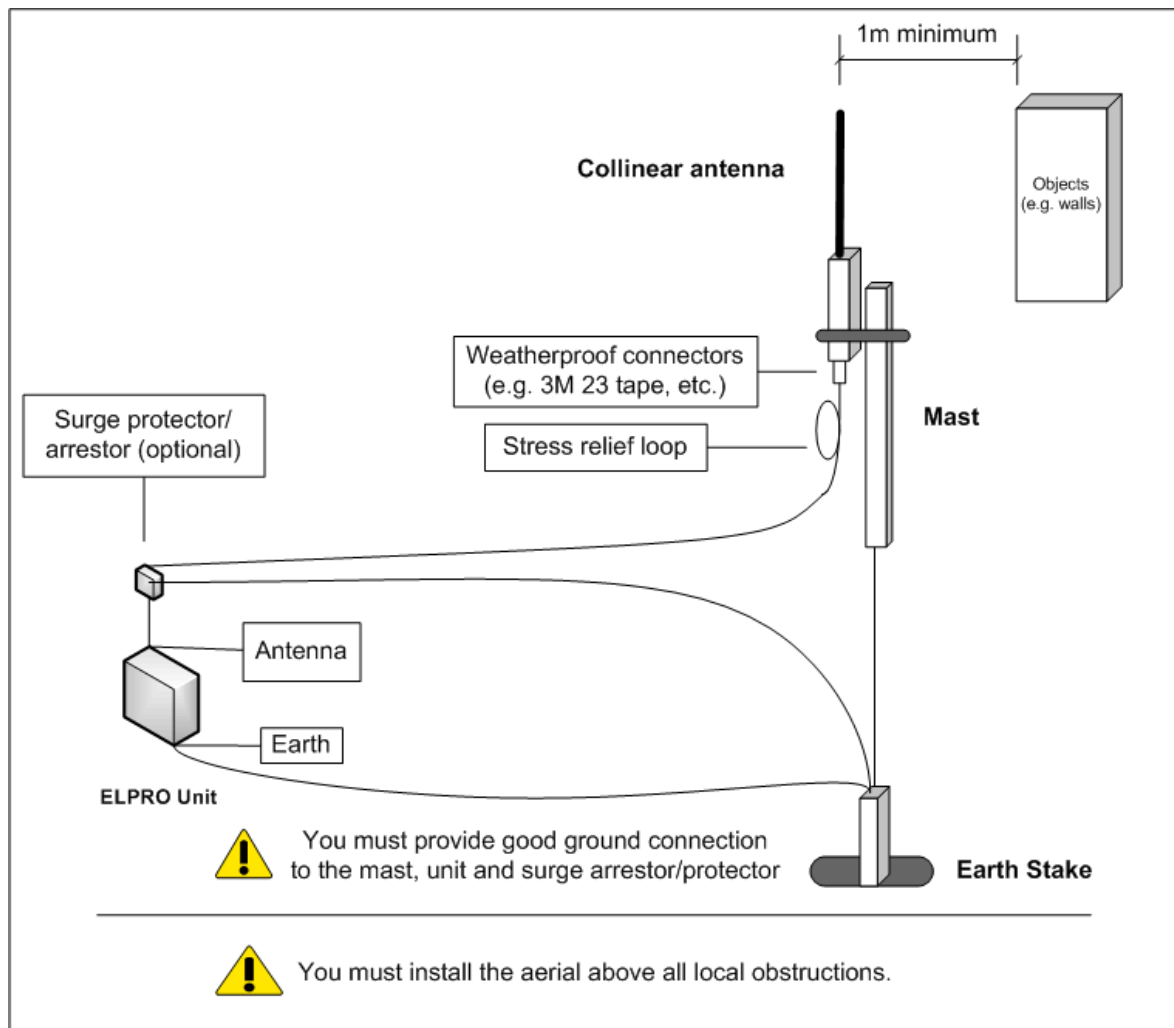

## Resetting your unit to factory defaults

To reset the default factory configuration:

1. Set the RSSI rotary switch to position 0 using a screwdriver.
2. Power on the WI-I/O 9-L-T transmitter.
3. The WI-I/O 9-L-T transmitter flashes all LEDs at medium flash (i.e. 1.6 Hz).

**NOTE:** If the LEDs do not flash, you must repeat steps 1 and 2 until the LEDs flash before continuing.

4. Set the RSSI rotary switch to another position (i.e. position 1) within 5 seconds.
5. Set the RSSI rotary switch to position 0 within another 5 seconds.
6. The WI-I/O 9-L transmitter lights all LEDs for 2 seconds before returning to normal operation.

**NOTE:** If the LEDs do not light for 2 seconds, you must repeat the process from step 1 until the LEDs light before continuing.

7. You can now link the transmitter and receiver units.

## Linking your transmitter and receiver units

You must reset the transmitter unit to factory defaults (to disable encryption) before linking the transmitter and receiver units. For more information, see the previous section.

**NOTE:** You must complete the linking process in 60 seconds.

To link the transmitter and receiver units:

1. Press and hold down the RSSI Pushbutton on the receiver.
2. Power on the receiver while holding down the RSSI Pushbutton
3. Release the RSSI Pushbutton as soon as the Receiver LEDs flash (within 5 seconds of powering the receiver).
4. The receiver will flash all LEDs for a maximum 60 seconds while it tries to link to the transmitter.
5. Power on the transmitter. The transmitter sends a special "Link" message to allow the receiver to recognise the transmitter.
6. When the units link, the receiver lights all LEDs for 2 seconds before returning to normal operation.

**NOTE:** If the receiver LEDs continue flashing within the 60 seconds, the units are not linked and you should retry the linking process by powering the transmitter off and on again. If you exceed the 60 seconds, you must restart the linking process from step 1.

7. You can now bench test your configuration before deploying.

## Safety information

Thank you for selecting the WI-I/O 9-L-T transmitter for your telemetry needs. We trust it will give you many years of valuable service. To ensure your WI-I/O 9-L-T transmitter enjoys a long life, double-check **ALL** your connections with the user's manual before powering on the unit.

**WARNING:** Incorrect termination of supply wires may cause internal damage and will void warranty.

Exposure to RF energy is an important safety consideration. The FCC has adopted a safety standard for human exposure to radio frequency electromagnetic energy emitted by FCC regulated equipment as a result of its actions in Docket 93-62 and OET Bulletin 65 Edition 97-01.

### FCC Notice when used in USA: WI-I/O 9-L-T Module

Part	Additional information
15	This device has been tested and found to comply with the limits for a Class B digital device, pursuant to Part15 of the FCC rules (Code of Federal Regulations 47CFR Part 15). Operation is subject to the condition that this device does not cause harmful interference.
90	This device has been type accepted for operation by the FCC in accordance with Part90 of the FCC rules (47CFR Part 90). See the label on the unit for the specific FCC ID and any other certification designations.

### Industry Canada: Wireless I/O Module

RSS-119 - This device has been type accepted for operation by Industry Canada in accordance with RSS-119 of the Industry Canada rules. See the label on the unit for the specific Industry Canada certification number and any other certification designations.

**NOTE:** Any changes or modifications not expressly approved by Weidmuller Inc. could void the user's authority to operate this equipment.

To operate this equipment legally the user must obtain a radio-operating license from the government agency. This is done so the government can coordinate radio users in order to minimize interference.

### Safety information - FCC Notice

This device complies with Part 15.247 of the FCC Rules. Operation is subject to the following two conditions:

- This device may not cause harmful interference; and
- This device must accept any interference received, including interference that may cause undesired operation

**NOTE:** This equipment is suitable for use in Class 1 Division 2 groups A, B and C or non-hazardous locations only.

## Unit specifications

Input/output	Number	Additional information
Digital inputs	2	Dry-contact digital inputs slow-pulsed at 10Hz. All inputs are suitable for voltage free contacts (e.g. mechanical switches) or NPN transistor devices (e.g. electronic proximity switches). <b>NOTE:</b> PNP transistor device inputs are NOT suitable.
Analog inputs	1	0-20mA differential input; 16-bit resolution, 0.1% accuracy, 10 ohm input impedance.
Thermocouple inputs	1	J, K or T type thermocouple with on-board cold-junction compensation. Cold junction compensation accuracy $\pm 1^{\circ}$ over ambient temp range: $-40^{\circ}$ to $+70^{\circ}\text{C}$ .
Power supply	1	9-30 VDC 1 Amp CSA certified Class 2 power supply. For use in Class 1 Div 2 explosive areas, the power supply must be approved for Class 1 Div 2 use. <b>WARNING:</b> Explosion hazard - do not disconnect while circuit is live unless area is known to be non-hazardous.
Transmitter	1	1 Watt Frequency Hopping Spread Spectrum (FHSS) Transmitter.
Frequency	902-928 MHz	Actual frequency range depends on country.

## Document information

Quick Start Guide WI-I/O 9-L-T Wireless I/O Transmitter Unit

## Contact details

Address > 821 Southlake Blvd., Richmond, VA 23832  
Telephone > (800) 849-9343  
Fax > (804) 897-4136  
Email > [info@weidmuller.com](mailto:info@weidmuller.com)  
Website > [www.wireless.weidmuller.com](http://www.wireless.weidmuller.com)

## Limited lifetime warranty, disclaimer and limitation of remedies

Weidmuller Inc. products are warranted to be free from manufacturing defects for the “serviceable lifetime” of the product. The “serviceable lifetime” is limited to the availability of electronic components. If the serviceable life is reached in less than three years following the original purchase from Weidmuller Inc., Weidmuller Inc. will replace the product with an equivalent product if an equivalent product is available.

This warranty does not extend to:

- Failures caused by the operation of the equipment outside the particular product's specification, or
- Use of the module not in accordance with this User Manual, or
- Abuse, misuse, neglect or damage by external causes, or
- Repairs, alterations, or modifications undertaken other than by an authorized Service Agent.

Weidmuller Inc.'s liability under this warranty is limited to the replacement or repair of the product.

This warranty is in lieu of and exclusive of all other warranties. This warranty does not indemnify the purchaser of products for any consequential claim for damages or loss of operations or profits and Weidmuller Inc. is not liable for any consequential damages or loss of operations or profits resulting from the use of these products. Weidmuller Inc. is not liable for damages, losses, costs, injury or harm incurred as a consequence of any representations, warranties or conditions made by Weidmuller Inc. or its representatives or by any other party, except as expressed solely in this document.