

## Electronic Interface Modules

### G478 Ultra SlimPak®

#### Frequency Input, Field Configurable Isolator



- field configurable via DIP switches for different input-output combinations
- provides an isolated DC output in proportion to the input frequency
- easy field configurable input ranges from 2Hz to 10,000Hz
- eliminates ground loops with 1800Vdc input-to-output isolation
- 5 field configurable output ranges 0-5V, 0-10V, 0-1mA, 0-20mA, 4-20mA
- 50mV to 150V input amplitude level
- advanced "touch-sample" technology for simplified ranging
- flexible power supply accepts 9 to 30Vdc
- ASIC technology for high reliability
- CSA approved, UL recognized, CE marked

Weidmuller Ltd.  
10 Spy Court  
Markham, ON L3R 5H6  
Tel: (905)475-1507  
Fax: (905)475-5855

Weidmuller Ltd  
821 Southlake Blvd.  
Richmond, VA 23236 U.S.A.  
Tel: (804)794-2877  
Fax: (804)794-0252

ISO 9001 Registered

	1	2	3	4	5	6	7	8
0-5V	■	■	■	■	■	■	■	■
0-10V	■	■	■	■	■	■	■	■
0-1mA	■	■	■	■	■	■	■	■
4-20mA	■	■	■	■	■	■	■	■
0-20mA	■	■	■	■	■	■	■	■

KEY ■ = ON

Table 1: Output switch settings (SW1, 1 through 8)

SENS.	SW1
	9 10
HIGH	■
LOW	■

High: 0.5-10Vp  
150Vrms max.  
  
Low: 150mVp-1Vp  
50Vrms max.

Table 2: Input amplitude threshold sensitivity settings

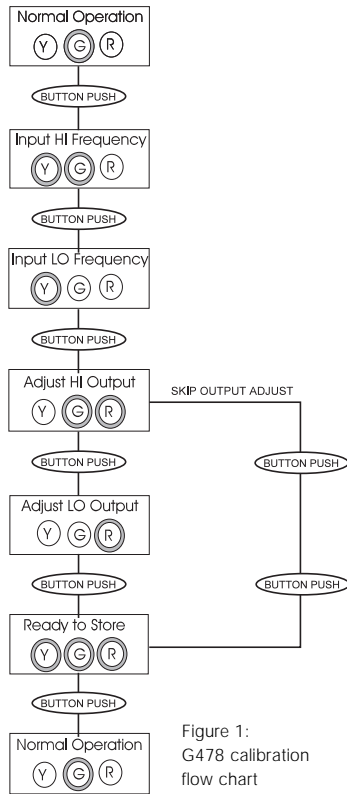
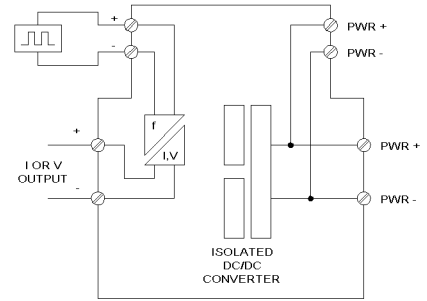

Figure 1: G478 calibration flow chart



## Description

The Ultra SlimPak Model G478 is a DIN rail mount, frequency input signal conditioner with 1800Vdc isolation between input, output and power. The field configurable input and output offer flexible, wide ranging capability for variable frequency drives, magnetic pick-ups, turbine flow meters, and other pulse or frequency output transducers.

The input of the G478 can be configured for any frequency span from 2Hz to 10,000Hz. The input amplitude threshold sensitivity can be adjusted from 150mVp to 10Vp to ensure accurate frequency measurement and minimize transient noise related errors. The maximum input amplitude is 150 Vrms. The output can be set for either 0-5V, 0-10V, 0-1mA, 0-20mA or 4-20mA.

Advanced digital technology allows the G478 to be field configured for virtually any frequency input to DC signal output within the ranges specified. Calibration utilizes 'Touch-Sample' technology where the user simply applies the minimum and maximum input frequencies, touching a recessed button to configure the corresponding minimum and maximum output range.

The very narrow Ultra SlimPak housing enables installations of up to 24 unit per linear foot. The wide ranging power supply is inverter isolated and accepts any voltage between 9 and 30Vdc.

## Application

The Ultra SlimPak G478 field configurable frequency input signal conditioner is useful in eliminating ground loops and interfacing pulse output transducers, such as turbine flow meters and magnetic pick-ups, to data acquisition and control systems.

Advanced digital technology, combined with ASIC technology, provides a stable output at low frequencies for higher accuracy, and three way isolation which completely eliminates ground loops from any source.

## 'Touch-Sample' Technology

The G478 utilizes 'Touch-Sample' technology which greatly simplifies configuration. To set the input frequency range, the user simply applies the high input frequency and pushes the CAL button while the INPUT LED is lit. The low input frequency is then input and pushing the CAL button again stores the low frequency input. The high and low ranges are stored in non-volatile memory and correspond to the high and low output range which is selected via DIP switches. To precisely adjust the output, the user adjusts the input frequency while the OUTPUT LED is lit until the desired output level is achieved. The output levels are locked-in by pushing the CAL button. Status LEDs show the operation mode of the device.

## Status LEDs

The G478 utilizes three status LEDs. One is a dual function LED signal monitor. This green LED indicates DC power and input signal status. Active line power is indicated by an illuminated LED. If the input signal is 10% more than full scale range, the LED will flash at 8Hz. Below 0%, the flash rate is 4Hz. The yellow INPUT LED, when on, denotes input programming modes. The red OUTPUT LED, when on, denotes output programming modes (see Configuration, Calibration and Figure 1 for details).

## Configuration

A major advantage of the G478 is its wide ranging capabilities and ease of configuration. The G478 enables virtually 99% zero and span adjustability. Any 2Hz range from 0 to 10,000Hz can be converted to a full scale output signal (e.g. 0-2Hz/4-20mA or 9998-10,000Hz/ 4-20mA).

Unless otherwise specified, the factory presets the Model G478 as follows:

Input Range: 0 to 1000Hz

Sensitivity: 1V RMS

Output Range: 4 to 20mA

Note: "Sensitivity" refers to the noise rejection level or the trigger threshold of the input.

For other I/O ranges, refer to Table 1 for output range (SW1, 1 through 8) switch settings and to Table 2 for sensitivity switch setting (SW1, 9 & 10). For quick and easy calibration mode reference, see the step-by-step flow chart in Figure 1.

1. With DC power off, choose the desired output voltage/current range from Table 1 and set position 1 through 8 of the output switch selector (SW1).

2. Set the Input sensitivity switch (SW1, 9 & 10) to LO for input amplitudes between 150mVp and 50Vrms, with noise rejection to 1Vp. Set SW2 to HI for input amplitudes between 500mVp and 150Vrms, with noise rejection up to 10Vp

**WARNING: Do not attempt to change any DIP SWITCH settings for the output (SW1) while power is applied. Severe damage will result!**

## Calibration

1. Connect the input to a calibrated frequency source and apply power. Wait 1 hour for thermal stability before monitoring the voltage or current output.

2. Adjust the input frequency to the desired maximum and observe that the output has increased and is sensing the input. If this is not observed, turn the sensitivity potentiometer in a counter-clockwise direction until the output changes proportionally to the input.

3. With the green LED on press the CAL button once to enter the calibration mode. The yellow and green LEDs should now be on.

4. Input the maximum desired frequency (if not done already) and press the CAL button to store. The yellow LED should now be the only LED on.

5. Input the minimum desired frequency and press the CAL button to store. The green and red LEDs should now be on.

Note: The most reliable way to input 0Hz is to short circuit the input pins (41&42).

6. To precisely adjust the maximum output, adjust the input frequency until the output reads within  $\pm 0.1\%$  of the maximum selected output range. This typically occurs near 90% of the HI input frequency. Press the CAL button to store the value. The red LED will now be on.

7. To precisely adjust the minimum output, lower the input frequency until the output reads within  $\pm 0.1\%$  of the minimum selected output. This typically occurs near 10% of the HI input frequency. Press the CAL button to store the value. The yellow and red LEDs should be on. The green LED should be dim.

8. Press the CAL button one final time to exit the calibration mode. The green LED should now be on.

9. Check the minimum and maximum input-to-output calibration. Repeat steps 1 through 8 if calibration is not within desired specifications.

Note 1: To skip Steps 6 and 7 (output adjustment), press CAL button two times after Step 5.

Note 2: Removing power to the unit at any time before Step 8 will restore previous settings and calibration.

## Optimal Sensitivity

If the amplitudes of the input frequency is within the sensitivity parameters (i.e. 150mVp - 1Vp for LO and 0.5Vp - 10Vp for HI), then the sensitivity parameters can be set for optimum noise rejection.

1. Set the input near midrange (50% input) or to a frequency that exhibits the minimum pulse amplitude.

2. Turn the sensitivity pot (SENS) clockwise (CW) until the output drops to minimum.

3. Turn the sensitivity pot counter-clockwise (CCW) a turn or two until the output returns to the previous level.

4. Run the input through the full frequency range to make sure that the pulses are sensed at both the low and high input frequencies. If the output drops out during this test, when the input freq.  $>0\%$  then turn the sensitivity pot counter-clockwise another turn or two until the output picks up. Repeat to validate sensitivity settings.

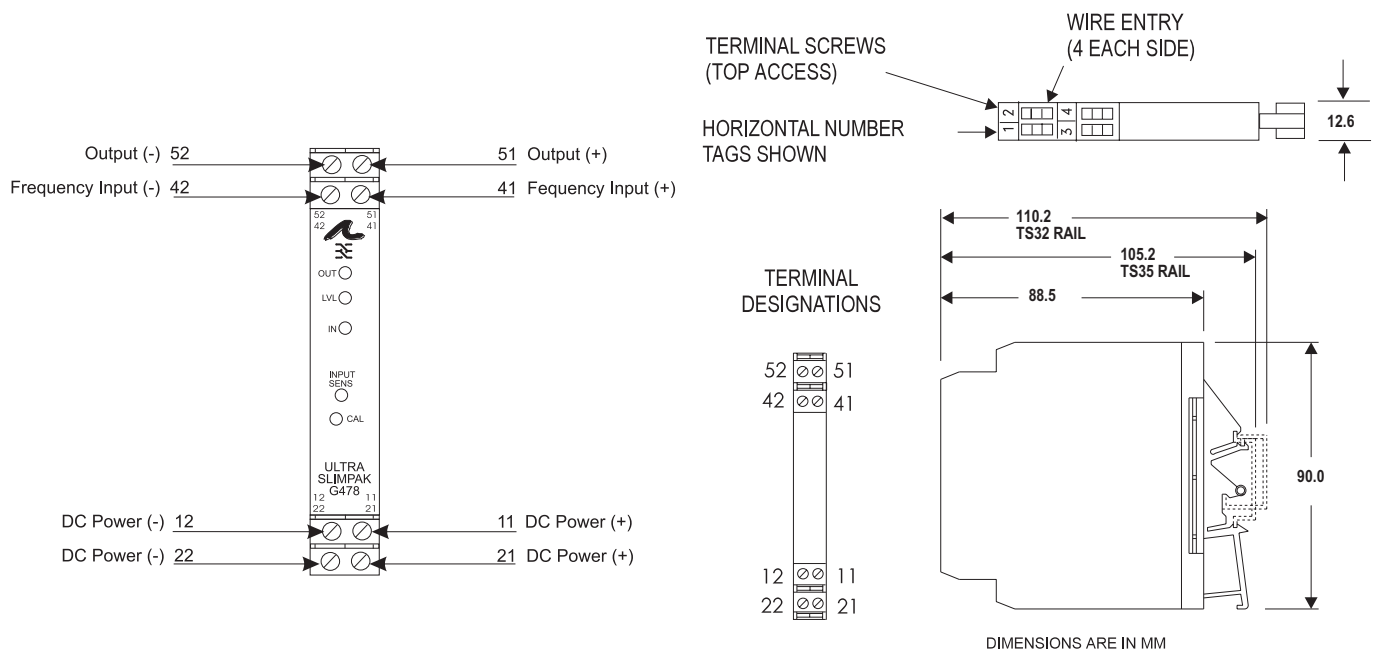

Rated data	
<b>Input</b>	Frequency signal (any wave shape)
Range	Frequency: 0-2Hz to 0-10kHz, selected with Advanced 'Touch-Sample' calibration button Amplitude: 150mVp to 150Vrms
Impedance	>10k $\Omega$
Maximum ratings / type of protection	20kHz, 180Vrms
Field device excitation	
Other input specification	
<b>Output</b>	DC current or voltage
Range	0-1mA, 0-20mA, 4-20mA, 0-5Vdc or 0-10Vdc, DIP switch selectable
Load	<7.5k $\Omega$ (0-1mA), <600 $\Omega$ (0/4-20mA), >500 $\Omega$ (0-5V), >1000 $\Omega$ (0-10V)
Burnout level	
Zero / Span adjustment	0 to 99% of full scale input (9998Hz) / 1 to 100% of full scale input (2Hz)
Protection	
Other output specification	Sensitivity adjustment: HI (0.5-10Vpeak) or LO (150mV - 1Vpeak), switch selectable, potentiometer adjustable
Other output specification	
<b>Supply</b>	DC voltage
Range	9 to 30Vdc, inverter isolated
Consumption	1.5W typ., 2.5W max. (300mA inrush at 9Vdc)
Other supply specification	
<b>General</b>	
Accuracy	$\pm$ 0.1% of selected range at 25°C
Linearity	included in accuracy
Temperature coefficient (drift)	$\pm$ 0.025% of selected range/°C maximum
Transmission frequency	
Response time. 90% span	500mS or 100 times the period of full scale frequency
Other general specification	
Status LED	input green, programming yellow (input range status), programming red (output range status)
Isolation (# of ports)	1800V (3 port) between input, output and power
Operating / Storage temperature	0 to 55°C / -25 to 70°C
Housing (mounting)	EG8 (TS32 and TS35)
Dimensions (L x W x H)	90mm x 12.7mm x 112.7mm max.
Wire range (conductor size)	22-12AWG (0.5-4.0mm <sup>2</sup> )
Insulation stripping length	7mm
Tightening torque	0.4-0.8Nm
Approvals	CSA (file LR-42272), UL (file E99775), CE marked (EMC dir. 89/336/EEC, LV dir. 73/23/EEC: Input<75Vpeak only)
<b>Ordering data</b>	<b>Cat. No.</b>
Ultra SlimPak	<b>G478</b> (factory calibration: 0-1kHz, 120Vac amplitude, 1Vpeak sensitivity, 4-20mA Out)
Heat sink (width)	<b>HS01-A (1.6mm)</b> (conditionally required depending on installation, see heat sink data)
Shunt resistor	
Note: G478-000X where X is the revision level	