

Application Note

Power Supply Configuration for Redundancy - Weidmuller power supplies from 6W to 150W

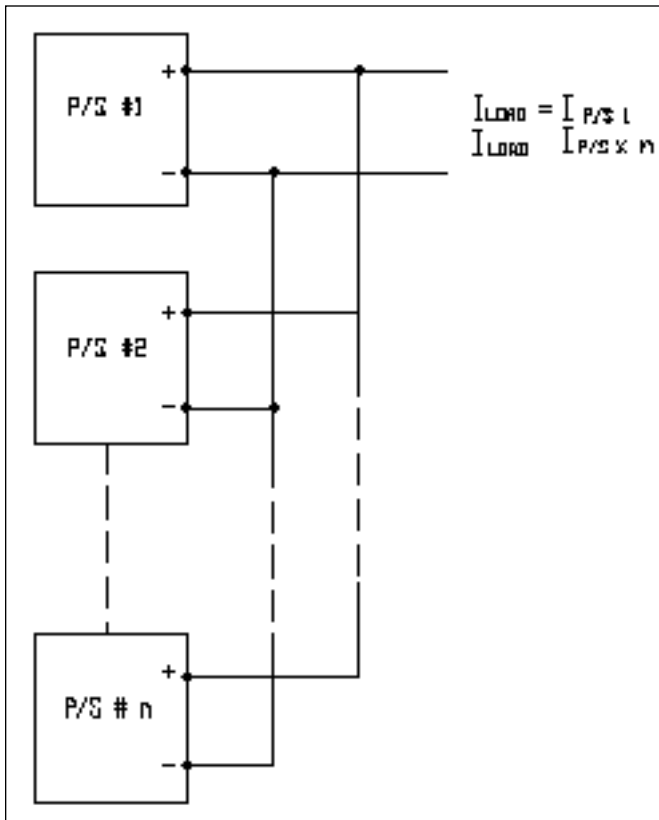

Weidmuller's switchmode power supplies can be connected in parallel for redundant operation. When configured this way the total load current cannot exceed the output rating of a single supply. For example, if two 990937's are connected in parallel the total load cannot exceed 5A even though each unit is rated 5A.

When connected in parallel one power supply will likely provide almost all of the load current while the other supply (or supplies) will deliver minimal load current unless the first supply fails. This is a typical redundancy application.

If a power supply fails its "DC Output" LED may be energized by the functioning supply (or supplies). This could be prevented by using diodes or Weidmuller's DC Current Sensor module cat.no. 991645. Consult factory for a data sheet and application note.

Please note that **parallel connection as a means of increasing the total load current capability is not recommended**. In order for power supplies to be operated this way each supply must either be designed specifically for parallel operation or they must be adjusted for exactly the same output voltage. They should also be operating at the same ambient temperature. As these two conditions are very difficult to maintain this configuration is not recommended.

Weidmuller's new connec+power 300W power supply, rated 24Vdc @12.5A, can be connected in parallel for both redundancy and increased current capacity. Consult factory for details.

Weidmuller Ltd.
10 Spy Court
Markham, ON L3R 5H6
Tel: (905)475-1507
Fax: (905)475-5855

Weidmuller Inc.
821 Southlake Blvd.
Richmond, VA 23236 U.S.A.
Tel: (800)849-9343
Fax: (804)379-2593

ISO 9001 Registered