

## Application

The 991625 power supply is designed to be operated in parallel, either for N+1 redundancy or for increased load currents. In both applications it is often important to know that a power supply has failed even though the remaining supplies have more than enough capacity to power the load(s).

One means of accomplishing this is to monitor the analog output representing the output voltage. This 0-10Vdc signal is proportional to a 0-30Vdc output voltage. If a power supply fails, this signal will drop to 0 volts even though 24Vdc is being supplied to the load by the remaining power supplies.

The compact MC5R relay module, catalog number 7901580000 is powered from the 24Vdc output of the power supplies but controlled by a separate 5-15Vdc nominal signal. The high impedance of the control input makes it compatible with the analog output on

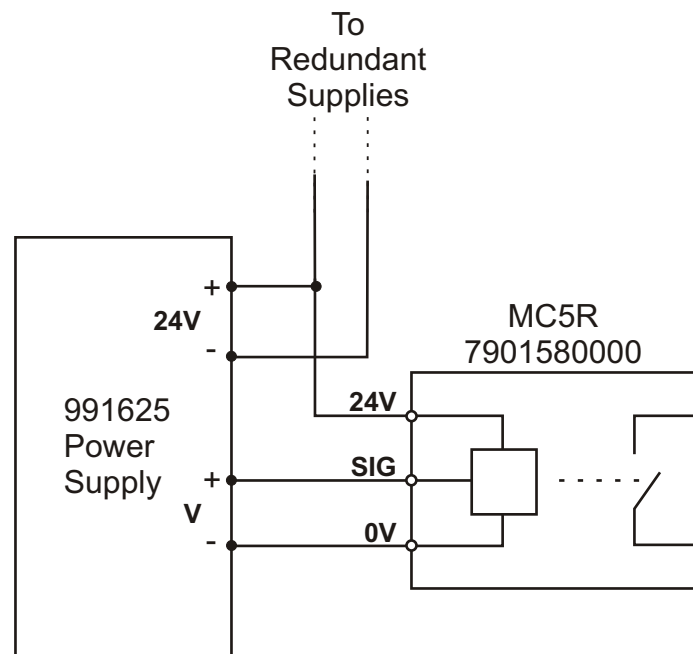

the 991625 power supply. As long as the output voltage exceeds approximately 3-3.5Vdc the relay will energize. This would represent an output from the power supply of approximately 9-10.5Vdc. Such a low voltage would represent a fault condition.

Another means of monitoring redundant power supplies is to monitor the current. Weidmuller offers several DC current monitoring modules. These range from a family of TRMS current transducers rated up to 60A offer analog outputs to a simple module that is user configurable for a current threshold of up to 6.5A. There is even a DIN rail mounted digital current meter rated up to 9.9A.

Canada  
Weidmuller Ltd.  
10 Spy Court  
Markham, Ontario L3R 5H6  
Telephone: (800) 268-4080  
Facsimile: (905) 475-2798  
Email: info1@weidmuller.ca  
Website: www.weidmuller.ca

**Weidmüller** 