

## T-SERIES Single-Phase Power Supplies

# NEW



The T-SERIES is a new generation of high performance DIN-rail mounted single-phase power supplies designed to work reliably even under demanding factory floor conditions. A high power reserve guarantees reliable start-up of loads with high inrush currents. Excellent electrical specifications and high immunity against fluctuations on input voltage makes these compact modules the best choice to power sensitive loads in industrial process control systems, machine tools or

other demanding industrial applications. The T-SERIES offers users easy installation with detachable screw terminal block and snap-on mounting on DIN-rails. All models offer a DC-OK signal and external shut down function. Redundant operation with true power sharing is available as an option.

The T-SERIES power supplies comply with the latest safety and EMC standards for industrial environments.

- Hazardous approvals for process automation applications
- Industrial grade design
- Rugged metal case for harsh industrial environments
- Autoselect input and international safety approvals
- Industrial operating temperature range:  $-25^{\circ}\text{C}$  to  $+70^{\circ}\text{C}$  (Cold start at full load at  $-25^{\circ}\text{C}$ )
- Variable output voltage
- Indefinite short circuit, overvoltage and overtemperature protection
- Power OK signal
- Remote On/Off
- Shock and vibration proof
- Optional panel mounting
- Redundancy module\*

\* Agency Approvals Pending

### Canada

Weidmüller, Canada  
10 Spy Court  
Markham, Ontario L3R 5H6  
Telephone: (800) 268-4080  
Facsimile: (905) 475-2798  
Email: [info1@weidmuller.ca](mailto:info1@weidmuller.ca)  
Website: [www.weidmuller.ca](http://www.weidmuller.ca)

### Mexico

Weidmüller, Mexico  
Blvd. Hermanos Serdán 698  
Col. San Rafael Oriente  
Puebla, Puebla, Mexico  
C.P. 72029  
Telephone: 01 222 2686267  
Facsimile: 01 222 2686219  
Email: [clientes@weidmuller.com.mx](mailto:clientes@weidmuller.com.mx)  
Website: [www.weidmuller.com.mx](http://www.weidmuller.com.mx)

### United States

Weidmüller  
821 Southlake Blvd.  
Richmond, Virginia 23236  
Telephone: (800) 849-9343  
Facsimile: (804) 379-2593  
Email: [info@weidmuller.com](mailto:info@weidmuller.com)  
Website: [www.weidmuller.com](http://www.weidmuller.com)

**Weidmüller** 

CP T SNT 70W 12V 6A

CP T SNT 140W 12V 12A

CP T SNT 90W 24V 3.8A

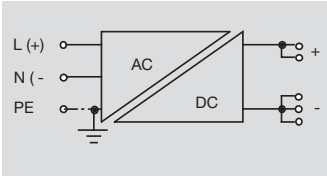

Technical Data

Input Specifications	CP T SNT 70W 12V 6A	CP T SNT 140W 12V 12A	CP T SNT 90W 24V 3.8A
Input voltage	115VAC/230VAC autoselect	115VAC/230VAC autoselect	115VAC/230VAC autoselect
Input voltage range	85-132/187-264 VAC autoselect (output current derating below 100VAC)*	85-132/187-264 VAC autoselect (output current derating below 100VAC)*	85-132/187-264 VAC autoselect (output current derating below 100VAC)*
Input voltage frequency	47Hz - 63Hz	47Hz - 63Hz	47Hz - 63Hz
Harmonic limits	EN 61000-3-2, Class A (for limited output power)	EN 61000-3-2, Class A (for limited output power)	EN 61000-3-2, Class A (for limited output power)
Hold up time	20ms min. 115/230 VAC	20ms min. 115/230 VAC	20ms min. 115/230 VAC
Inrush current	<12A @ 115VAC; <20A @ 230VAC	<13A @ 115VAC; <25A @ 230VAC	<12A @ 115VAC; <20A @ 230VAC
Recommended Circuit breaker, Curve 1 or fuse, slow blow type	6A	6A	6A
Efficiency	87% typ.	87% typ.	87% typ.
Output Specifications			
Output voltage	12 VDC	12 VDC	24 VDC
Output voltage adj. range	12-14 VDC	12-14 VDC	24-28 VDC
Output current	6.5A	13.0A	3.75A
Output power max.	70W	140W	90W
Regulation – Input variation	0.5 % max.	0.5 % max.	0.5 % max.
– Load variation (10–100 %)	0.5 % max.	0.5 % max.	0.5 % max.
Ripple and Noise (20MHz Bandwidth)	100 mV pk-pk typ. (200 mV pk-pk max. at I <sub>max</sub> )	100 mV pk-pk typ. (200 mV pk-pk max. at I <sub>max</sub> )	100 mV pk-pk typ. (200 mV pk-pk max. at I <sub>max</sub> )
Electronic short circuit protection	Current limitation at I <sub>max</sub> , constant current, automatic recovery	Current limitation at I <sub>max</sub> , constant current, automatic recovery	Current limitation at I <sub>max</sub> , constant current, automatic recovery
Output overvoltage protection	20V	20V	35V
Overload protection	electronic overload protection	electronic overload protection	electronic overload protection
Overtemperature protection	Switch off at overtemperature, automatic restart	Switch off at overtemperature, automatic restart	Switch off at overtemperature, automatic restart
Status indicator	Dual color LED (green: DC ok; red: DC off)	Dual color LED (green: DC ok; red: DC off)	Dual color LED (green: DC ok; red: DC off)
Power OK signal – trigger threshold:	9–11 V	9–11 V	18–22 V
– active output signal: (reference to –Vout)	11.0 V ±1.0 V (20 mA max.)	11.0 V ±1.0 V (20 mA max.)	22.0 V ±2.0 V (10 mA max.)
– relay output	rated: 30 VDC/1.0 A	rated: 30 VDC/1.0 A	rated: 30 VDC/1.0 A
General Specifications			
Operating temperature range	–25 °C to +70 °C max. (–13 °F to +158°F)**	–25 °C to +70 °C max. (–13 °F to +158°F)**	–25 °C to +70 °C max. (–13 °F to +158°F)**
Cooling	convection cooling, no internal fan	convection cooling, no internal fan	convection cooling, no internal fan
Mounting	TS35 DIN-rail (Horizontal) to allow for cooling	TS35 DIN-rail (Horizontal) to allow for cooling	TS35 DIN-rail (Horizontal) to allow for cooling
Storage temperature	–25 °C to +85 °C (–13 °F to +185°F)	–25 °C to +85 °C (–13 °F to +185°F)	–25 °C to +85 °C (–13 °F to +185°F)
Humidity (non condensing)	95 % rel. H max.	95 % rel. H max.	95 % rel. H max.
Pollution degree	2	2	2
Temperature coefficient	0.02 %/K	0.02 %/K	0.02 %/K
Reliability, calculated MTBF @ 25°C acc. to IEC 61709	>1.8 Million hours, max. load	>1.2 Million hours, max. load	>1.8 Million hours, max. load
Remote On/Off	by ext. contact.	by ext. contact.	by ext. contact.
(See LIT0917 - Installation Instructions)	DC on: -S contact open DC off: -S connected via 1Kohm to -Vout according to IEC/EN 60950-1, UL 60950-1, UL 508	DC on: -S contact open DC off: -S connected via 1Kohm to -Vout according to IEC/EN 60950-1, UL 60950-1, UL 508	DC on: -S contact open DC off: -S connected via 1Kohm to -Vout according to IEC/EN 60950-1, UL 60950-1, UL 508
Isolation			
Environment – Vibration acc. IEC 60068-2-6; – Shock acc. IEC 60068-2-27	3 axis, sine sweep, 10–55 Hz, 1 g, 1 oct/min 3 axis, 15 g half sine, 11 ms	3 axis, sine sweep, 10–55 Hz, 1 g, 1 oct/min 3 axis, 15 g half sine, 11 ms	3 axis, sine sweep, 10–55 Hz, 1 g, 1 oct/min 3 axis, 15 g half sine, 11 ms
Dimension (W x D x H)	35 x 110 x 110 mm	54 x 110 x 110 mm	35 x 110 x 110 mm
Clearances – Above/Below – Sides	80 mm (3.15 in) 10 mm (0.39 in)	80 mm (3.15 in) 10 mm (0.39 in)	80 mm (3.15 in) 10 mm (0.39 in)
Weight	0.5kg	0.7kg	0.5kg
Approvals	See Approvals Table, page 6	See Approvals Table, page 6	See Approvals Table, page 6

Ordering Data

Type	Part No.	Type	Part No.	Type	Part No.
CP T SNT 70W 12V 6A	1105430000	CP T SNT 140W 12V 12A	1105440000	CP T SNT 90W 24V 3.8A	1105790000

\* See Graph B, page 8

\*\*See Graph A, page 8

CP T SNT 180W 24V 7.5A

CP T SNT 360W 24V 15A

CP T SNT 600W 24V 25A

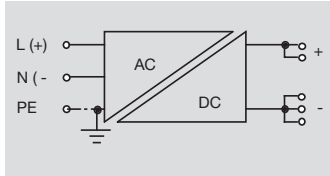

Technical Data

Input Specifications	CP T SNT 180W 24V 7.5A	CP T SNT 360W 24V 15A	CP T SNT 600W 24V 25A
Input voltage	115VAC/230VAC autoselect	115VAC/230VAC autoselect	115VAC/230VAC autoselect
Input voltage range	85-132/187-264 VAC autoselect (output current derating below 100VAC)*	85-132/187-264 VAC autoselect (output current derating below 100VAC)*	85-132/187-264 VAC autoselect (output current derating below 100VAC)*
Input voltage frequency	47Hz - 63Hz	47Hz - 63Hz	47Hz - 63Hz
Harmonic limits	EN 61000-3-2, Class A (for limited output power)	EN 61000-3-2, Class A (for limited output power)	EN 61000-3-2, Class A (for limited output power)
Hold up time	20ms min. 115/230 VAC	20ms min. 115/230 VAC	20ms min. 115/230 VAC
Inrush current	<13A @ 115VAC; <25A @ 230VAC	<16A @ 115VAC; <25A @ 230VAC	<25A @ 115VAC; <30A @ 230VAC
Recommended Circuit breaker, Curve 1 or fuse, slow blow type	6A	10A	15A
Efficiency	87% typ.	87% typ.	87% typ.
Output Specifications			
Output voltage	24 VDC	24 VDC	24 VDC
Output voltage adj. range	24-28 VDC	24-28 VDC	24-28 VDC
Output current	7.5A	15A	25A
Output power max.	180W	360W	600W
Regulation – Input variation	0.5 % max.	0.5 % max.	0.5 % max.
– Load variation (10–100 %)	0.5 % max.	0.5 % max.	0.5 % max.
Ripple and Noise (20MHz Bandwidth)	100 mV pk-pk typ. (200 mV pk-pk max. at I <sub>max</sub> )	100 mV pk-pk typ. (200 mV pk-pk max. at I <sub>max</sub> )	100 mV pk-pk typ. (200 mV pk-pk max. at I <sub>max</sub> )
Electronic short circuit protection	Current limitation at I <sub>max</sub> , constant current, automatic recovery	Current limitation at I <sub>max</sub> , constant current, automatic recovery	Current limitation at I <sub>max</sub> , constant current, automatic recovery
Output overvoltage protection	35V	35V	35V
Overload protection	electronic overload protection	electronic overload protection	electronic overload protection
Overtemperature protection	Switch off at overtemperature, automatic restart	Switch off at overtemperature, automatic restart	Switch off at overtemperature, automatic restart
Status indicator	Dual color LED (green: DC ok; red: DC off)	Dual color LED (green: DC ok; red: DC off)	Dual color LED (green: DC ok; red: DC off)
Power OK signal – trigger threshold:	18-22 V	18-22 V	18-22 V
– active output signal: (reference to -Vout)	22.0 V ±2.0 V (20 mA max.)	22.0 V ±2.0 V (20 mA max.)	22.0 V ±2.0 V (20 mA max.)
– relay output	rated: 30 VDC/1.0 A	rated: 30 VDC/1.0 A	rated: 30 VDC/1.0 A
General Specifications			
Operating temperature range	-25 °C to +70 °C max. (-13 °F to +158°F)**	-25 °C to +70 °C max. (-13 °F to +158°F)**	-25 °C to +70 °C max. (-13 °F to +158°F)**
Cooling	convection cooling, no internal fan	convection cooling, no internal fan	convection cooling, no internal fan
Mounting	TS35 DIN-rail (Horizontal) to allow for cooling	TS35 DIN-rail (Horizontal) to allow for cooling	TS35 DIN-rail (Horizontal) to allow for cooling
Storage temperature	-25 °C to +85 °C (- 13°F to +185°F)	-25 °C to +85 °C (- 13°F to +185°F)	-25 °C to +85 °C (- 13°F to +185°F)
Humidity (non condensing)	95 % rel. H max.	95 % rel. H max.	95 % rel. H max.
Pollution degree	2	2	2
Temperature coefficient	0.02 %/K	0.02 %/K	0.02 %/K
Reliability, calculated MTBF @ 25°C acc. to IEC 61709	>0.9 Million hours, max. load	>0.9 Million hours, max. load	>0.9 Million hours, max. load
Remote On/Off	by ext. contact.	by ext. contact.	by ext. contact.
(See LIT0917 - Installation Instructions)	DC on: -S contact open DC off: -S connected via 1Kohm to -Vout according to IEC/EN 60950-1, UL 60950-1, UL 508	DC on: -S contact open DC off: -S connected via 1Kohm to -Vout according to IEC/EN 60950-1, UL 60950-1, UL 508	DC on: -S contact open DC off: -S connected via 1Kohm to -Vout according to IEC/EN 60950-1, UL 60950-1, UL 508
Isolation			
Environment – Vibration acc. IEC 60068-2-6; – Shock acc. IEC 60068-2-27	3 axis, sine sweep, 10–55 Hz, 1 g, 1 oct/min 3 axis, 15 g half sine, 11 ms	3 axis, sine sweep, 10–55 Hz, 1 g, 1 oct/min 3 axis, 15 g half sine, 11 ms	3 axis, sine sweep, 10–55 Hz, 1 g, 1 oct/min 3 axis, 15 g half sine, 11 ms
Dimension (W x D x H)	54 x 110 x 110 mm	80 x 125 x 125 mm	165 x 125 x 125 mm
Clearances – Above/Below – Sides	80 mm (3.15 in) 10 mm (0.39 in)	80 mm (3.15 in) 10 mm (0.39 in)	80 mm (3.15 in) 10 mm (0.39 in)
Weight	0.7kg	1.1kg	2.8kg
Approvals	See Approvals Table, page 6	See Approvals Table, page 6	See Approvals Table, page 6

Ordering Data

Type	Part No.	Type	Part No.	Type	Part No.
CP T SNT 180W 24V 7.5A	1105810000	CP T SNT 360W 24V 15A	1105820000	CP T SNT 600W 24V 25A	1105840000

\* See Graph B, page 8  
\*\*See Graph A, page 8

CP T SNT 180W 48V 4A

CP T SNT 360W 48V 7.5A

CP T SNT 600W 48V 12.5A

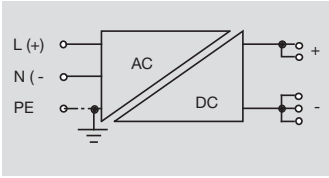

Technical Data

Input Specifications	CP T SNT 180W 48V 4A	CP T SNT 360W 48V 7.5A	CP T SNT 600W 48V 12.5A
Input voltage	115VAC/230VAC autoselect	115VAC/230VAC autoselect	115VAC/230VAC autoselect
Input voltage range	85-132/187-264 VAC autoselect (output current derating below 100VAC)*	85-132/187-264 VAC autoselect (output current derating below 100VAC)*	85-132/187-264 VAC autoselect (output current derating below 100VAC)*
Input voltage frequency	47Hz - 63Hz	47Hz - 63Hz	47Hz - 63Hz
Harmonic limits	EN 61000-3-2, Class A (for limited output power)	EN 61000-3-2, Class A (for limited output power)	EN 61000-3-2, Class A (for limited output power)
Hold up time	20ms min. 115/230 VAC	20ms min. 115/230 VAC	20ms min. 115/230 VAC
Inrush current	<13A @ 115VAC; <25A @ 230VAC	<16A @ 115VAC; <25A @ 230VAC	<25A @ 115VAC; <30A @ 230VAC
Recommended Circuit breaker, Curve 1 or fuse, slow blow type	6A	10A	15A
Efficiency	87% typ.	87% typ.	87% typ.
Output Specifications			
Output voltage	48 VDC	48 VDC	48 VDC
Output voltage adj. range	48-56 VDC	48-56 VDC	48-56 VDC
Output current	4.0A	7.5A	12.5A
Output power max.	180W	360W	600W
Regulation – Input variation	0.5 % max.	0.5 % max.	0.5 % max.
– Load variation (10–100 %)	0.5 % max.	0.5 % max.	0.5 % max.
Ripple and Noise (20MHz Bandwidth)	100 mV pk-pk typ. (200 mV pk-pk max. at I <sub>max</sub> )	100 mV pk-pk typ. (200 mV pk-pk max. at I <sub>max</sub> )	100 mV pk-pk typ. (200 mV pk-pk max. at I <sub>max</sub> )
Electronic short circuit protection	Current limitation at I <sub>max</sub> , constant current, automatic recovery	Current limitation at I <sub>max</sub> , constant current, automatic recovery	Current limitation at I <sub>max</sub> , constant current, automatic recovery
Output overvoltage protection	60V	60V	60V
Overload protection	electronic overload protection	electronic overload protection	electronic overload protection
Overtemperature protection	Switch off at overtemperature, automatic restart	Switch off at overtemperature, automatic restart	Switch off at overtemperature, automatic restart
Status indicator	Dual color LED (green: DC ok; red: DC off)	Dual color LED (green: DC ok; red: DC off)	Dual color LED (green: DC ok; red: DC off)
Power OK signal – trigger threshold:	36-46 V	36-46 V	36-46 V
– active output signal: (reference to –Vout)	44.0 V ±4.0 V (15 mA max.)	44.0 V ±4.0 V (15 mA max.)	44.0 V ±4.0 V (15 mA max.)
– relay output	rated: 48 VDC/0.5 A	rated: 48 VDC/0.5 A	rated: 48 VDC/0.5 A
General Specifications			
Operating temperature range	–25 °C to +70 °C max. (–13 °F to +158°F)**	–25 °C to +70 °C max. (–13 °F to +158°F)**	–25 °C to +70 °C max. (–13 °F to +158°F)**
Cooling	convection cooling, no internal fan	convection cooling, no internal fan	convection cooling, no internal fan
Mounting	TS35 DIN-rail (Horizontal) to allow for cooling	TS35 DIN-rail (Horizontal) to allow for cooling	TS35 DIN-rail (Horizontal) to allow for cooling
Storage temperature	–25 °C to +85 °C (–13°F to +185°F)	–25 °C to +85 °C (–13°F to +185°F)	–25 °C to +85 °C (–13°F to +185°F)
Humidity (non condensing)	95 % rel. H max.	95 % rel. H max.	95 % rel. H max.
Pollution degree	2	2	2
Temperature coefficient	0.02 %/K	0.02 %/K	0.02 %/K
Reliability, calculated MTBF @ 25°C acc. to IEC 61709	>0.9 Million hours, max. load	>0.9 Million hours, max. load	>0.9 Million hours, max. load
Remote On/Off	by ext. contact.	by ext. contact.	by ext. contact.
(See LIT0917 - Installation Instructions)	DC on: -S contact open DC off: -S connected via 1Kohm to -Vout according to IEC/EN 60950-1, UL 60950-1, UL 508	DC on: -S contact open DC off: -S connected via 1Kohm to -Vout according to IEC/EN 60950-1, UL 60950-1, UL 508	DC on: -S contact open DC off: -S connected via 1Kohm to -Vout according to IEC/EN 60950-1, UL 60950-1, UL 508
Isolation			
Environment – Vibration acc. IEC 60068-2-6; – Shock acc. IEC 60068-2-27	3 axis, sine sweep, 10–55 Hz, 1 g, 1 oct/min 3 axis, 15 g half sine, 11 ms	3 axis, sine sweep, 10–55 Hz, 1 g, 1 oct/min 3 axis, 15 g half sine, 11 ms	3 axis, sine sweep, 10–55 Hz, 1 g, 1 oct/min 3 axis, 15 g half sine, 11 ms
Dimension (W x D x H)	54 x 110 x 110 mm	80 x 125 x 125 mm	165 x 125 x 125 mm
Clearances – Above/Below – Sides	80 mm (3.15 in) 10 mm (0.39 in)	80 mm (3.15 in) 10 mm (0.39 in)	80 mm (3.15 in) 10 mm (0.39 in)
Weight	0.7kg	1.1kg	2.8kg
Approvals	See Approvals Table, page 6	See Approvals Table, page 6	See Approvals Table, page 6

Ordering Data

Type	Part No.	Type	Part No.	Type	Part No.
CP T SNT 180W 48V 4A	1105850000	CP T SNT 360W 48V 7.5A	1105860000	CP T SNT 600W 48V 12.5A	1105870000

\* See Graph B, page 8

\*\*See Graph A, page 8

**Redundancy Modules\***

With a redundancy module and two T-SERIES power supplies (of same type) you can configure a highly reliable, truly redundant power system without any additional components. This module enforces the equivalent sharing of the output current by each power supply. The system is fully redundant and provides output power even if one power supply has completely failed e.g. by short circuit on the output. In the event that either power supply fails or is disconnected, the second unit will automatically supply the full current to the load. The redundancy of the system is monitored and if lost, indicated by an alarm output. The inputs are hot swappable and can be loaded up to 15 A each.

\* Agency Approvals Pending

**CP T RM 10  
Redundancy Module**



**CP T RM 20  
Redundancy Module**



**Technical Data**

Input Specifications	CP T RM 10	CP T RM 20
Input	2 x 24 VDC	2 x Control Input
Input current	15A	25A
Output Specifications		
Output voltage	24 VDC	24 VDC
Output voltage adj. range	24-27 VDC	24-27 VDC
Output power max.	360 W	600 W
Output current	15A @ 24VDC, @ 40°C	25A @ 24VDC, @ 40°C
General Data		
Status indicator	LED	LED
Operating temperature	-25 °C to 70 °C max. (-13 °F...+158 °F) derating above 40 °C (104 °F): 1.5 %/K trigger threshold at 18...22VDC, contact open if both inputs failed	-25 °C to 70 °C max. (-13 °F...+158 °F) derating above 40 °C (104 °F): 1.5 %/K trigger threshold at 18...22VDC, contact open if both inputs failed
Redundancy OK signal (Alarm)		
MTBF in acc. To IEC 61709	>350,000 hours, max. load	>350,000 hours, max. load
Alarm relay contact	30VDC/1A	
Environment - Vibration	3 axis, sine sweep, 10...55Hz, 1g, 1oct/min. 3 axis, 15g half sine, 11ms	3 axis, sine sweep, 10...55Hz, 1g, 1oct/min. 3 axis, 15g half sine, 11ms
Environment - Shock		
Dimension (W x D x H)	35 x 110 x 110 mm	54 x 110 x 110 mm
Weight	0.5kg	0.7kg
Remote link cable (0.5m)	2 cables included	2 cables included
Remote On/Off	by ext. contact: contact open = On, contact closed = Off	by ext. contact: contact open = On, contact closed = Off
Approvals	Agency Approvals Pending	Agency Approvals Pending

**Ordering Data**

Type	Part No.	Type	Part No.
CP T RM 10	1105880000	CP T RM 20	1105890000

**Function Diagram**

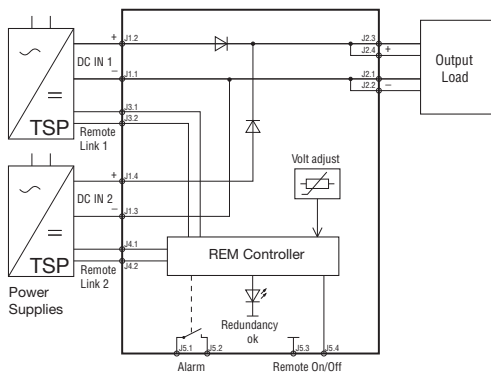

**Connector Positions**

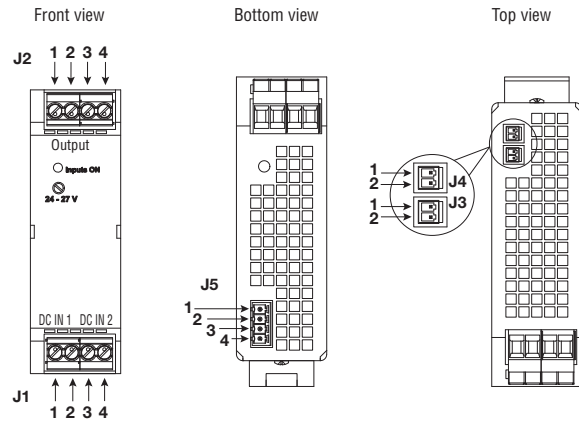

For detailed installation instructions, please visit [www.weidmuller.com/power\\_supplies](http://www.weidmuller.com/power_supplies) and download LIT0917

	J1	J2	J3 Voltage Control 1 For Input 1	J4 Voltage Control 2 For Input 2	J5
Pin 1	Input 1 -Vin	GND (-)	S+	S+	DC-OK Signal
Pin 2	Input 1 +Vin	GND (-)	S-	S-	DC-OK Relay Contact
Pin 3	Input 2 -Vin	Vout (+)	-	-	Remote ON/OFF
Pin 4	Input 2 +Vin	Vout (+)	-	-	Remote ON/OFF

Agency Approvals

UL file E236157	cULus Listed to UL508, CSA C22.2 No. 14
UL file E255651	cRUus to ANSI/UL60950, CSA60950
CSA file 246286	CSA to C22.2 No. 107.1
CSA file 246286	cCSAus to CSA60950, ANSI/UL60950
CSA file 246286	cCSAus C1D2 to C22.2 No. 213
CSA file 246286	cCSAus C1Z2 to CSA60079-15 & ANSI/ISA 12.012.01
IEC file SI-1729 B3	CE marked

CP T SNT 70W 12V 6A  
CP T SNT 90W 24V 3.8A

Weight: 0.5kg (1.0lb)

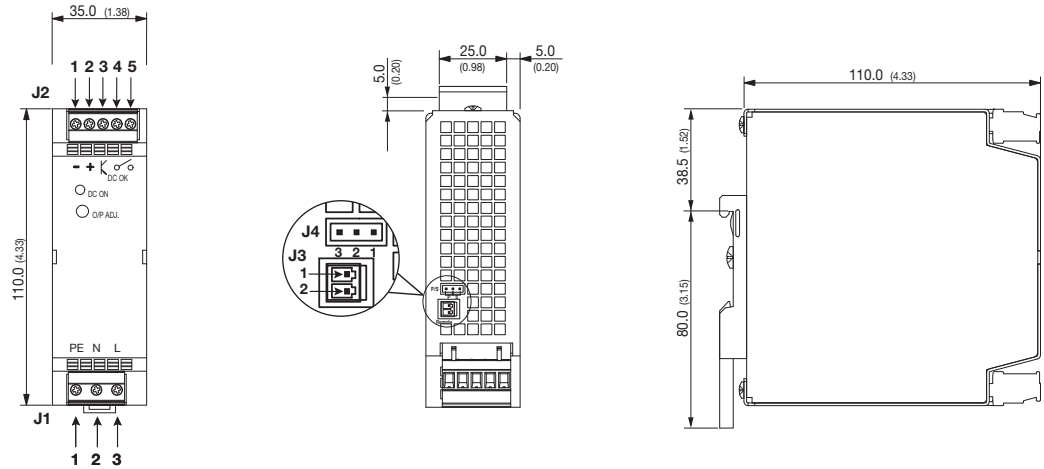

	J1	J2	J3	J4
Pin 1	Earth	GND (-)	S+	Normal Mode
Pin 2	Neutral	Vout (+)	S-	Common
Pin 3	Live	DC-OK Signal	-	Parallel Mode
Pin 4	-	DC-OK Relay Contact 1	-	-
Pin 5	-	DC-OK Relay Contact 2	-	-

CP T SNT 140W 12V 12A  
CP T SNT 180W 24V 7.5A  
CP T SNT 180W 48V 4A

Weight: 0.7kg (1.4lb)

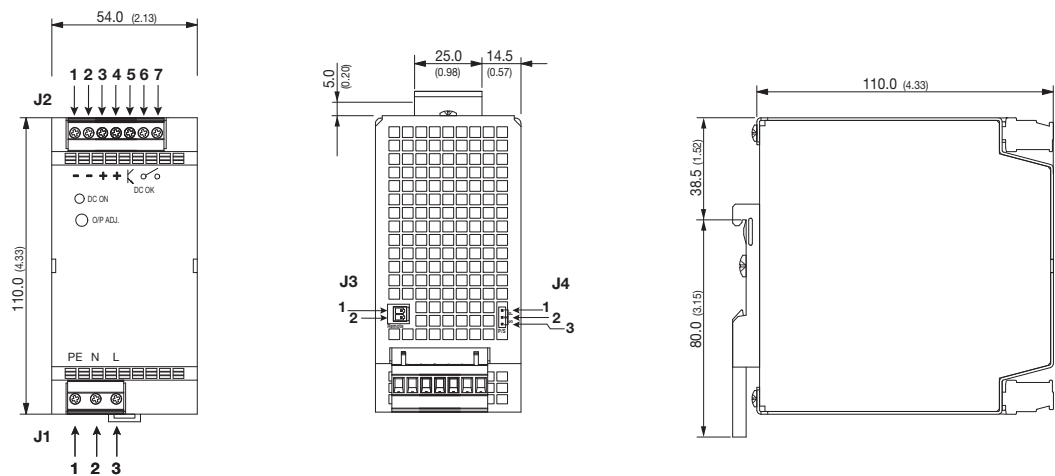

	J1	J2	J3	J4
Pin 1	Earth	GND (-)	S+	Normal Mode
Pin 2	Neutral	GND (-)	S-	Common
Pin 3	Live	Vout (+)	-	Parallel Mode
Pin 4	-	Vout (+)	-	-
Pin 5	-	DC-OK Signal	-	-
Pin 6	-	DC-OK Relay Contact 1	-	-
Pin 7	-	DC-OK Relay Contact 2	-	-

Dimensions in [mm], ( ) = inch  
Tolerances: ±0.5 mm (±0.02)

For detailed installation instructions, please visit [www.weidmuller.com/power\\_supplies](http://www.weidmuller.com/power_supplies) and download LIT0917

CP T SNT 360W 24V 15A  
 CP T SNT 360W 48V 7.5A

Weight: 1.1kg (2.4lb)

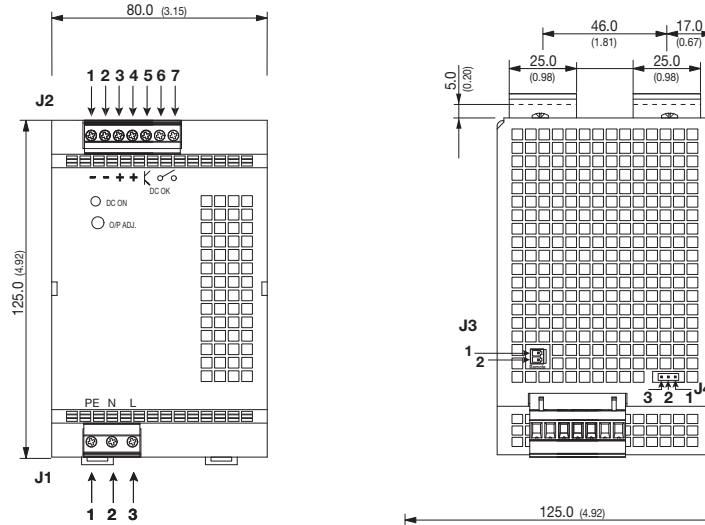

	J1	J2	J3	J4
Pin 1	Earth	GND (-)	S+	Normal Mode
Pin 2	Neutral	GND (-)	S-	Common
Pin 3	Live	Vout (+)	-	Parallel Mode
Pin 4	-	Vout (+)	-	-
Pin 5	-	DC-OK Signal	-	-
Pin 6	-	DC-OK Relay Contact 1	-	-
Pin 7	-	DC-OK Relay Contact 2	-	-

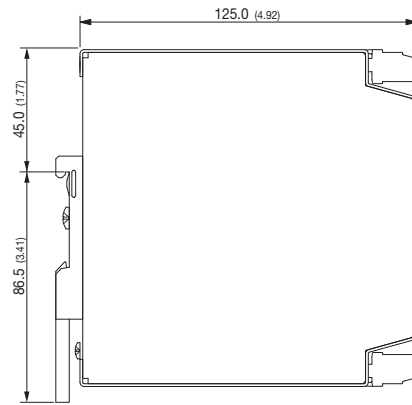

CP T SNT 600W 24V 24A  
 CP T SNT 600W 48V 12.5A

Weight: 2.8kg (6.0lb)

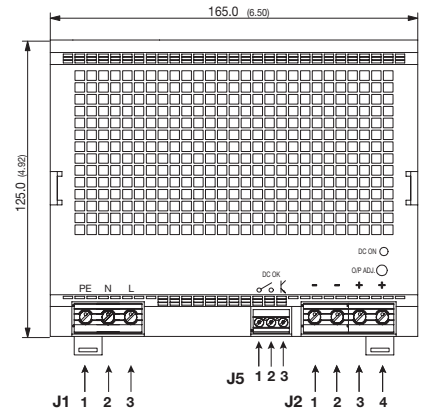
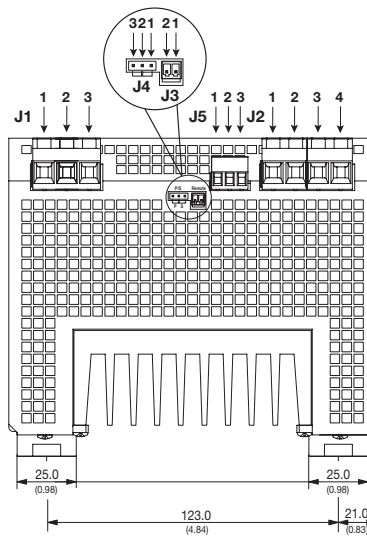

	J1	J2	J3	J4	J5
Pin 1	Earth	GND (-)	S+	Normal Mode	DC-OK Relay Contact 1
Pin 2	Neutral	GND (-)	S-	Common	DC-OK Relay Contact 2
Pin 3	Live	Vout (+)	-	Parallel Mode	DC-OK Signal
Pin 4	-	Vout (+)	-	-	-

Dimensions in [mm], ( ) = inch  
 Tolerances: ±0.5 mm (±0.02)

For detailed installation instructions, please visit [www.weidmuller.com/power\\_supplies](http://www.weidmuller.com/power_supplies)

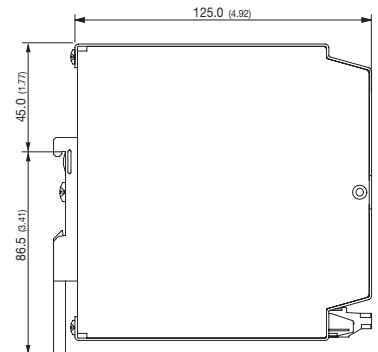

Power Supplies  
Output Power Derating

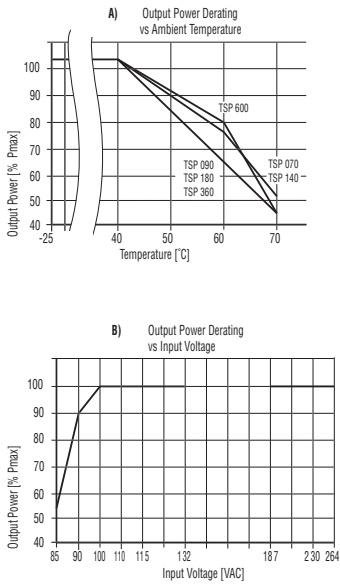

Wall Mounting Bracket

Ordering Data	Type	For Models	Content of Kit
1129210000	CP MB01	CP T SNT 70W, 90W, 140W, 180W	1 bracket type A
1129200000	CP MB02	CP T SNT 360W, 600W	2 brackets type B

Type A:

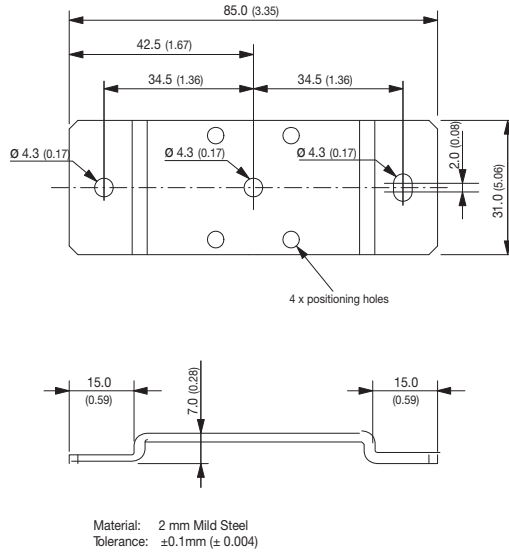

CP T SNT 70W, 90W

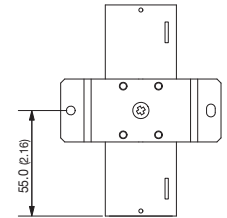

CP T SNT 140W, 180W

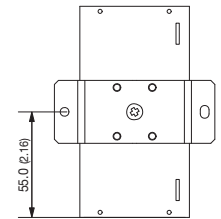

Trip Curve

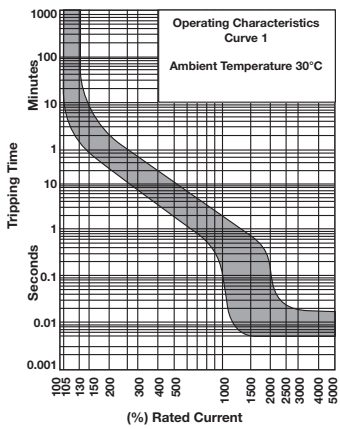

Type B:

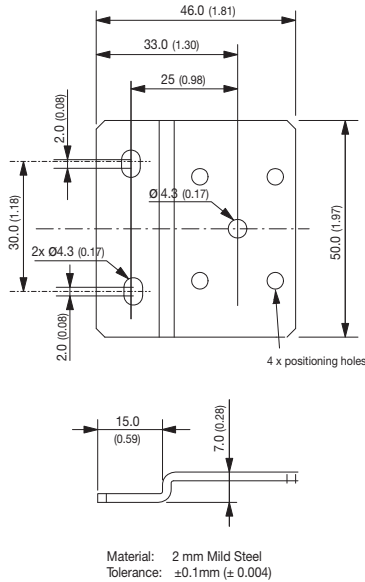

CP T SNT 360W

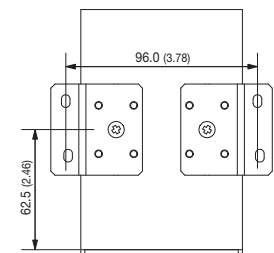

CP T SNT 600W

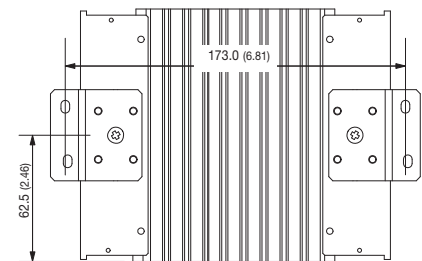

Dimensions: [mm] ( ) = Inch

For detailed installation instructions, please visit [www.weidmuller.com/power\\_supplies](http://www.weidmuller.com/power_supplies) and download LIT0917