

## Frequently Asked Questions

### MANN SERIES

**Q: Where is Signal Conditioning used?**

**A:** Analog signal conditioning is used in all types of electronic industrial and marine measurement and control systems, for example in processes such as power plants, steelworks, water and waste plant, oil and gas production and chemical processing. In fact, wherever temperature, pressure, level, flow, weight, speed etc. is measured and controlled as part of a continuous or batch production process. Such measurement parameters, after being accurately produced, must not be degraded on their way from the field to the control room, despite external influences from the atmosphere and installation, such as wide ambient temperature changes, electromagnetic interference, vibration, corrosive or hazardous environments.

**Q: What functions do analog signal conditioners provide?**

**A:** Analog signal conditioners provide one or more of the following functions:

1. Isolation of high level DC measurement and control signals.
2. Conversion of high level signals, such as 0...5 V input to 4...20 mA output.
3. Amplify, linearize and transmit low level sensor inputs, such as mV from thermocouples, into high level DC outputs to enable transmission over distances 100 meters or more.
4. Initiate status indications and alarms by creating relay contact closure outputs from analog inputs.

**Q: What is signal isolation?**

**A:** In most processes there are pieces of electronic measurement and control equipment from many different manufacturers. The signals from these instruments are interconnected to each other and to sensors, transducers and output devices connected in the process loop. In any such measurement and control system there are several electrical interfacing problems that are likely to occur, all of which can be solved by incorporating the appropriate signal isolator between the signals. A signal isolator is a device that can measure a signal from a common industrial sensor or transmitter and replicates it in the same form or converts it to another standard industrial signal with no direct ac or dc electrical connection between the input and output. For more detailed information on this subject please see our White Paper issue 06/2004 "What is Isolation?".

**Q: What Signal Conditioning products does Weidmuller offer?**

**A:** Weidmuller offers various Signal Conditioning product lines such as the WAVESERIES which modules are ideal when users need analog separating transducers, and the MICROSERIES and MCZ-SERIES, which is a range of temperature transmitters and DC isolators, packaged in a slim 6 mm housing. Weidmuller also offers AD/DA converters in their RS-SERIES, current monitoring modules in their CMA-SERIES and preprocessing logic modules in their DK-SERIES. Weidmuller's newest addition to the Signal Conditioning portfolio is the MANN SERIES.

**Q: What is the MANN SERIES?**

**A:** The MANN SERIES is complementary to Weidmüller's WAVESERIES, and is a range of signal conditioning products targeted towards the process industries. The product series, ranging from simple dedicated units to complex microprocessor-controlled devices, can be used with almost all signal types and measurement sensors. The products also offer a variety of integrated functions, such as timing delays, adjustable threshold values and a programmable ramping function.

**Q: What is included in the MANN SERIES?**

**A:** Included in the MANN SERIES are:

1. **Signal isolators** – for typical facility-based analog current and voltage signals. They eliminate the measurement errors caused by ground loops or electromagnetic interference. Type TWI 1/TWI 2, SFI/DFI and WAVEPak DC/DC.



2. **Signal transmitters** – to convert, filter and isolate any low-level signals coming from typical measuring devices. This includes mV signals from thermocouples and PT100 measurement probes, which are converted into normalized current or voltage signals. Type ITXPlus, STG, Micromann AR and Micromann UPI.



3. **Process alarms** – special two channel modules which monitor facility-specific measurement values. When necessary, they issue alarms to external monitoring systems. Type DPA and Micromann R.



**4. Multi-channel processing modules** – compact modules which are capable of processing multiple inputs, outputs and alarms simultaneously. When necessary, they can transmit analog or digital values, based on certain results, to a control system. Type Micromann Multiplus.



**5. Indicators and configurable displays** – available in a variety of designs, ranging from simple versions powered by current loops, to configurable products with integrated analog and alarm outputs. Type PMX420, PMX400, DI350, LPD350, LPD450F and AMS400A.



**6. Counters/Totalizers** – can be used for measuring flow rates and total. They can process analog and digital inputs signals (pulses). Type PTX800.



**7. Calibration devices** – to complete the product offering. They are specially designed for calibrating and setting analog signal-processing devices. Type Portacal 275 and Portacal 1000.



**Q: Which Industry is the right fit for the MANN SERIES?**

**A:** The MANN SERIES is targeted at the process industries. With its accuracy better than 0.1% (typically 0.05%) the products in the MANN SERIES are especially suitable for sensitive signals. The extruded aluminum housings make the products rugged enough for the harsh environment of the heavy industry.

**Q: What are the advantages of the MANN SERIES?**

**A:** The MANN SERIES is complementary to Weidmüller's WAVESERIES and offers a greater number of settable options, adjustable through the module front, than other Signal Conditioning products. Extruded aluminum housings give the MANN SERIES a robust and secure feel for heavy industry users. Highly adjustable the series offers high accuracy (Typically 0.05%) and stability while storing data securely through either passwords or cable-link security.

The MANN SERIES offers robust hand-held calibrators for routine loop checking for easy transmitter and valve checking. Front panel mounting instruments display process values with simple, calibrated digital LCD or LED displays or with powerful configurable indicating conditioners and monitors. The MANN SERIES offers the unique ITXPlus transmitter, which is a single product that can accept most analog sensor types (temperature and DC) and provides an isolated output-loop-powered 4...20 mA signal.

Other features of the MANN SERIES are universal isolators with adjustable voltage/current I/O, user-settable characterizing/linearizing outputs, optional power provided for input transmitters, multi-channel monitors with serial communications (RS485/Modbus), 8 digit indicating Flow Monitor with analog or pulse input options, auto-manual station with integral analog or pulse control and software configuration applications.

**Q: What are the differences to the WAVE SERIES and other Weidmüller Signal Conditioning products?**

**A:** The MANN SERIES offers a complete signal conditioning solution and a greater number of settable options for the process industry. It offers more accuracy and stability. Its extruded aluminum housing makes it suitable for harsh environments in the heavy process industry. It also offers LCD and LED monitors displaying process values.

**Q: When should I use products of the MANN SERIES over products of the WAVE SERIES or other Weidmüller Signal Conditioning products?**

**A:** The products of the MANN SERIES have advantages over the WAVESERIES or other Weidmüller Signal Conditioning products for the following types of applications:

1. Where customers need panel mounted display conditioners
2. Where customers need rail mounted input display modules
3. Where customers prefer front adjustment rather than Dip Switches
4. Where customers would like to minimize cabling and wiring need in refurbishment and add-on jobs by using the universal output loop powered ITX Plus module
5. Where customers want an easy and quick way to check transmitters and valves by using portable loop calibrators
6. Where customers need shortened cycle times and fewer I/O devices to reduce installation, cabling and maintenance cost by using multi-channel processing modules.

**Q: Is the MANN SERIES available in the USA?**

**A:** The US launch of the MANN SERIES is scheduled for May 2008. With the official launch a variety of MANN SERIES products will be made available from stock in Richmond, VA. A full launch package with training material, sales tools etc. will be made available at the time of the product launch.

**Q: Can you give me some examples of signal conditioning applications?**

**A:**

**Applications in a Process Plant**

**1 INCOMING / OUTGOING DELIVERIES**

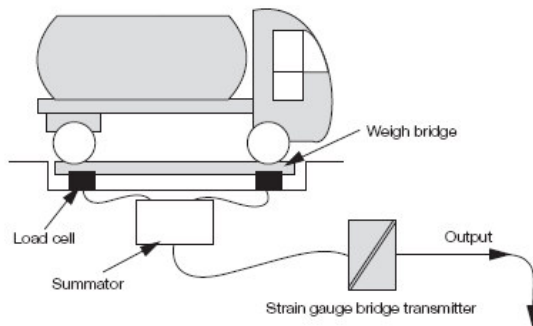

Product: Transmitter types **WAVE PRO Bridge** or **MANN SERIES STG**  
Load cells beneath a "weigh bridge" create a small mV measurement, which is isolated and amplified into a linear DC output (e.g. 4...20 mA) for display and recording.

**2 RAW MATERIALS BULK STORAGE**

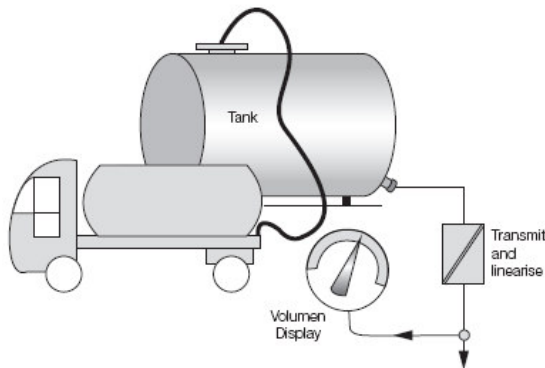

Product: Transmitter **ITXPlus**  
Level measurements often need conversion to volume, for the tank contents display for the filling operator. ITXPlus has user-definable linearization to suit any tank shape.

Product: Field mounted display **LPD450F**  
Where a weatherproof loop powered display is needed for visualisation.

**3 MIXING / BLENDING LIQUIDS**

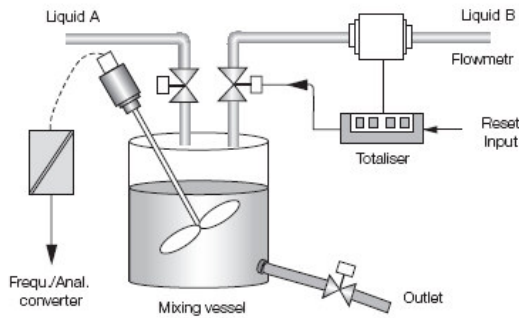

Product: Totalizer / Counter **MANN PTX800**

Batch control may involve close control of liquid volumes to be metered and mixed. PTX 800 can accept pulse or analogue inputs from flowmeters.

Product: Frequency transmitter **WAVE PRO Frequency** or **MANN UHZAR**

Mixing quality may depend on controlling the mixer speed as the level varies. Shaft speed can be converted to an isolated analogue output, to be the input to the speed controller.

**4 HEAT EXCHANGER CONTROL**

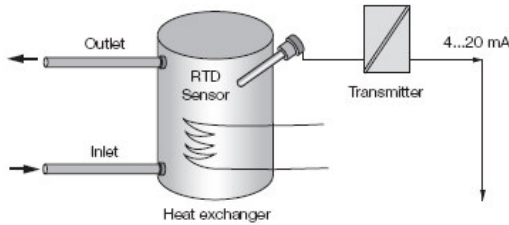

Product: Temperature transmitter **WAVE PRO RTD** or **ITXPlus**

Typically an RTD probe senses the product temperature. The transmitter amplifies and isolates the sensor input into a linear DC output (e.g. 4...20 mA), to be the input to the heating element controller.

**5 FINAL PRODUCT STORAGE**

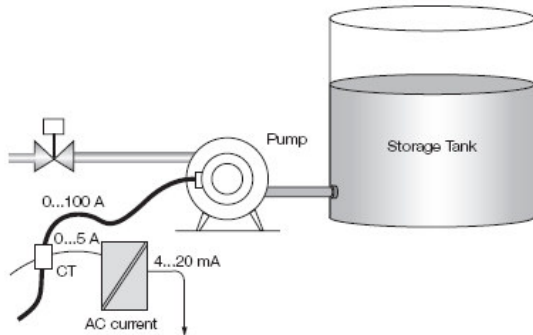

Product: Current converter **WAVE Control WAS1 CMA LP**

Pump monitoring may be done by measuring the AC current consumed by the pump motor, with a current transformer (CT). The CT output, typically 0...5 A can be isolated and converted to DC (e.g. 4...20 mA), to be the input for the control system.

## 6 DEDICATED DISPLAYS

Product: Loop splitter **WAS5 CCC OLP** or **MANN DFI**

Some parameters are important enough to be separately displayed apart from the control system. Incoming DC signals can be split and isolated to maintain the integrity of each function.

Product: **MANN DI350** or **MANN LPD 350**

Simple display of process parameters can include scaling in engineering units, and either auxiliary or loop power options.

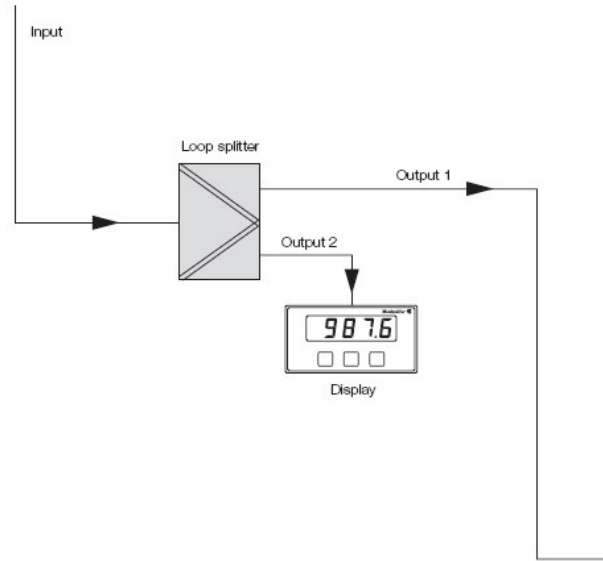

## 7 NON-ISOLATED INPUTS

Product: Isolator **WAVEpak DC/DC** or **MAS DC/DC Select**

Control systems with non-isolated analogue input cards often need separate external isolators. The external isolator can also convert the incoming signal if needed, and provide power for the signal source.

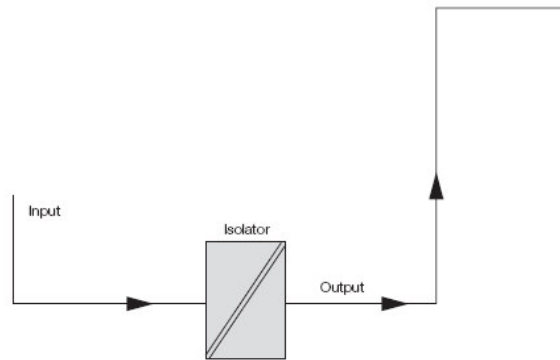

## 8 AUTO-MANUAL SWITCHING

Product: **MANN AMS 400A**

Controlling systems manually is sometimes needed – e.g. during process start-ups - and to switch smoothly between auto control and manual is important. The auto-manual switch is located between the control system output and the control device actuator, and may need to handle either analogue or digital input or output signals.

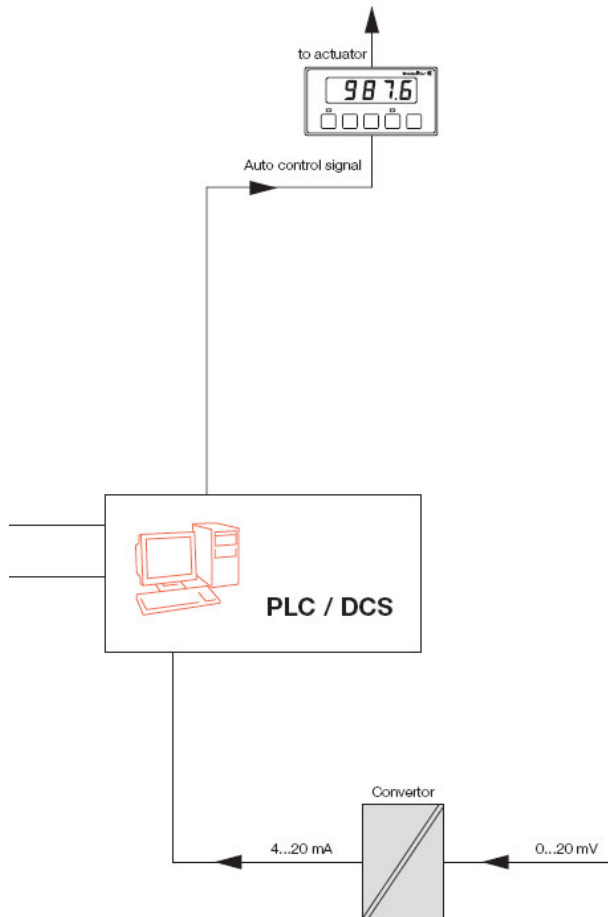

## 9 NON-STANDARD INPUTS

Product: Converter / isolator **WAVE PRO DC/DC**

Control systems analogue input ranges are usually limited – often to just 4...20 mA. A flexible converter / isolator to cover DC inputs spans from 20 mV to 200 V is a valuable tool.